

Formulate Tablet Kiosk - 03

TABLET-STD-03

Sleekly-designed free standing tablet stands and kiosks make it easy to encourage interactivity, present information and engage your customers in any space.



features and benefits:

- State-of-the-art 30mm aluminum tube frame with sturdy internal spigot assembly
- Easy to store and ship
- Quick to set up
- Includes the large tablet shell.
Small shell is available upon request.
- Kit includes: one frame, one dye-sublimated pillowcase graphic, tablet holder, and one wheeled molded OCE storage case
- Lifetime hardware warranty against manufacturer defects

dimensions:

Hardware

Assembled unit:
19.982" w x 64.335" h x 15.203" d
507.5mm(w) x 1634mm(h) x 386mm(d)

Approximate weight (includes graphic):
16.38 lbs / 7.43 kg

Shipping

Shipping dimensions:
1 OCE-2 case: 18" l x 18" w x 40" h up to
66" h 457mm(l) x 457mm(w) x 1016mm(h)
up to 1675mm(h)

Approximate shipping weight (with case):
37.38 lbs / 16.95 kg

Graphic

Refer to related graphic template for more information.

Visit:
www.exhibitors-handbook.com/graphic-templates

additional information:

Graphic material:
Dye-sublimated pillowcase fabric

Tablet not included

*Reference page 2 for tablet size compatibility



This product may include the following materials for recycle:
aluminum, select wood, fabric, cardboard, paper, steel, and plastics.

We are continually improving and modifying our product range and reserve the right to vary the specifications without prior notice. All dimensions and weights quoted are approximate and we accept no responsibility for variance. E&OE. See Graphic Templates for graphic bleed specifications.

Choosing Your Size

Use the table below to determine the correct shell size for your tablet.

Common Tablets	Height	Width	Dept	Weight	Screen Size	Shell Size
iPad Tablets						
1st Gen iPad Pro 11 (2018)	9.74"	7.02"	0.23"	1 lb.	11"	Large
2nd Gen iPad Pro 11 (2017)	9.74"	7.02"	0.23"	1 lb.	11"	Large
1st Gen iPad Pro 12 (2017)	12.04"	8.69"	0.27"	1.53 lb.	12.9"	Large
2nd Gen iPad Pro 12 (2017)	12.04"	8.69"	0.27"	1.53 lb.	12.9"	Large
3th Gen iPad Pro 12.9 (2017)	11.04"	8.46"	0.23"	1.4 lb.	12.9"	Large
4th Gen iPad Pro 12.9 (2017)	11.04"	8.46"	0.23"	1.4 lb.	12.9"	Large
New iPad (2018)	9.4"	6.6"	0.29"	1 lb.	9.7"	Small
iPad mini 4	8"	5.3"	0.24"	.66 lb.	7.9"	Small
1st Gen Ipad Air	9.4"	6.6"	0.29"	1.05 lb.	9.7"	Large
2nd Gen Ipad Air	9.4"	6.6"	0.24"	.96 lb.	9.7"	Large
3rd Gen iPad Air (2019)	9.87"	6.85"	0.24"	1 lb.	10.5"	Large
iPad Pro 10.5	9.8"	6.8"	0.24"	1 lb.	10.5"	Large
Ipad Mini 2	7.87"	5.3"	0.29"	.73 lb.	7.9"	Small
Ipad Mini 3	7.87"	5.3"	0.29"	.73 lb.	7.9"	Small
Ipad Mini 4	8"	5.3"	0.24"	0.65 lb.	7.9"	Small
Ipad Mini 5	8"	5.3"	0.24"	0.66 lb.	7.9"	Small
1st Gen Ipad	9.56"	7.74"	0.50"	1.5 lb.	9.7"	Large
2nd Gen Ipad	9.5"	7.3"	0.35"	1.33 lb.	9.7"	Large
3rd Gen Ipad	9.5"	7.3"	0.37"	1.43 lb.	9.7"	Large
4th Gen Ipad	9.5"	7.3"	0.37"	1.43 lb.	9.7"	Large
5th Gen Ipad	9.4"	6.6"	0.29"	1.43 lb.	9.7"	Large
6th Gen Ipad	9.4"	6.6"	0.29"	1.03 lb.	9.7"	Large
7th Gen Ipad	9.87"	6.85"	0.3"	1.09 lb.	10.2	Large
8th Gen Ipad	9.8"	6.8"	0.29"	1.08 lb.	10.2	Large
Android Tablets						
Samsung Galaxy Tab S3	9.34"	6.65"	0.24"	1 lb.	9.7"	Small
Samsung Galaxy Tab S4	9.81"	6.47"	0.28"	1 lb.	10.5"	Large
Microsoft Surface Pro	11.5"	7.9"	0.33"	1.73 lb.	12.3"	Large
Asus ZenPad 3S 10	9.47"	6.44"	0.28"	1 lb.	9.7"	Large
Kindle Fire 10	10.3"	6.3"	0.4"	1.1 lb.	10.1"	Large
Google Nexus 9	8.99"	6.05"	0.31"	1 lb.	8.9"	Small

*Small shell is available. Contact sales rep for more information.

Parts Included		
Part Code	Qty.	Description
5/16-18-FLANGE-WING-NUT	4	5/16"-18 zinc alloy flange wing nut (1 1/8" wing spread)
SET-SCRW-5/16X18X2	4	5/16-18 x 2" Hex socket set screw cup point ZINC
HEX-KEY-SET	1	5541A31 7pc (Silver) hex key for cables
STD-03 BASE	1	Base for the Tablet STD 03
STD-03-G	1	FABRIC GRAPHIC FOR STD-03
TC-30MM-SILVER	2	30mm silver anodized tube clamp
CAM-LOCK-2010	1	Cam Lock
ES30	1	ES30 EXPANDING SPIGOT FOR 30MM TUBE
OCE	1	Expanding plastic case
WP-1	2	Welding plate 1
TUBE-30MM-3937-S	3	Tube 30mm, 3937 (155") clean ANO, 6063T5 Die #12103
TC-30-L	1	30MM TUBING ADAPTOR WITH LOCK
TABLET-STD-ESS-SHELL-LG	1	Tablet stand essential large shell (bracket only) 10.5"-13" screen size displays
TABLET-STD-ESS-SHELL-PLEX	1	Tablet stand essential 6MM plex cover with PM4R8-MP mounting plate on back and mounting hardware

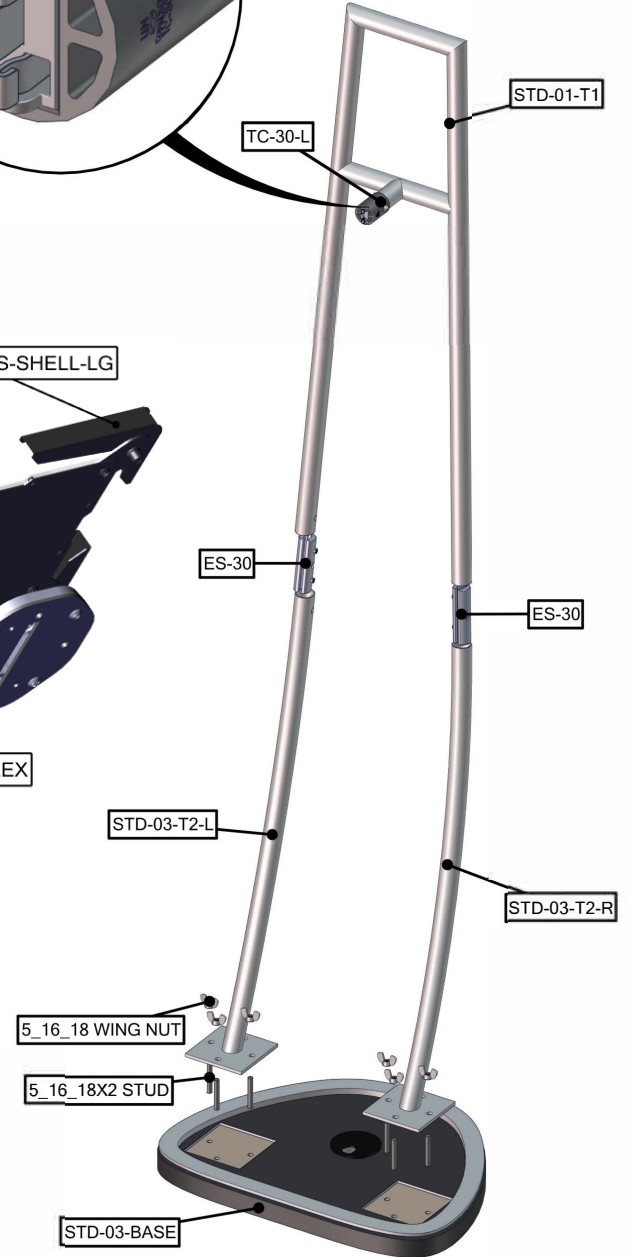
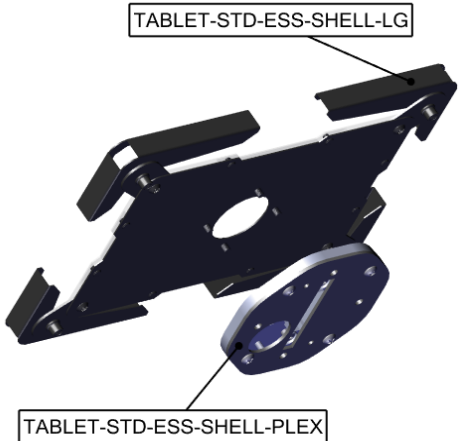
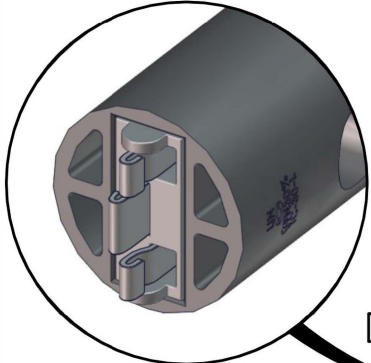

STEP 1: ASSEMBLE FRAME

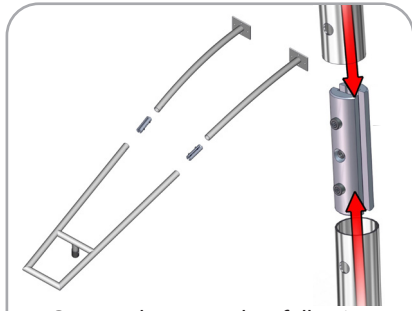

Connect bottom tubes following the labels by matching number to number. Slide joiner into tubing so hex screw sits in hole on tubing.

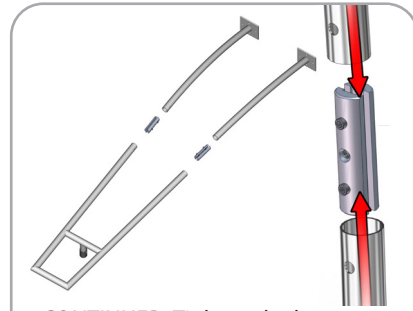

CONTINUED: Tighten the hex screw so the joiner separates and tightens against the inside of the tubing, locking the joiner & tubing together.

STEP 2: ATTACH BASE



Once frame is assembled, position frame over base to attach.

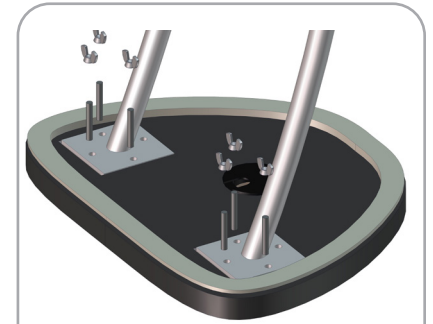

Insert threaded rods by hand. Tighten wing nuts to secure base.

STEP 3: ATTACH GRAPHIC

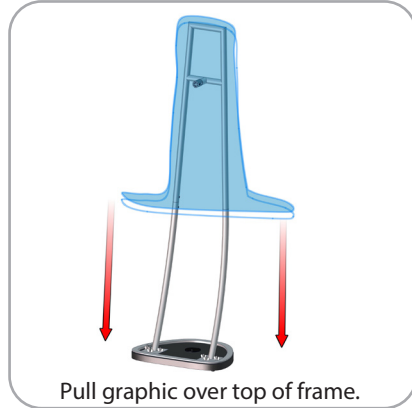

Pull graphic over top of frame.

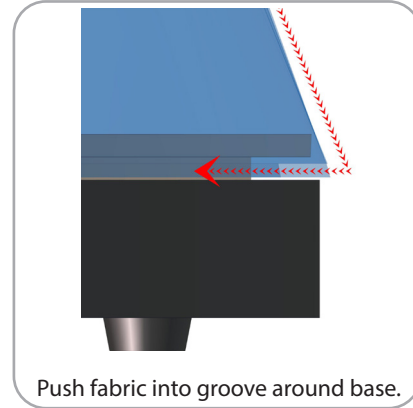

Push fabric into groove around base.

STEP 4: INSTALL TABLET HOLDER

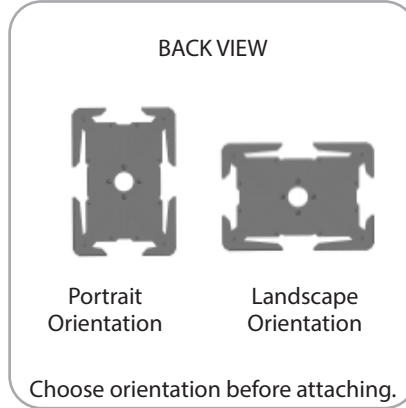

Line up tablet holder middle holes with TABLET-STD-ESS-SHELL-PLEX holes. Insert screws into front of bracket as show. tighten until secure. Do not over tighten. Orientation can not be changed without removing screws first.

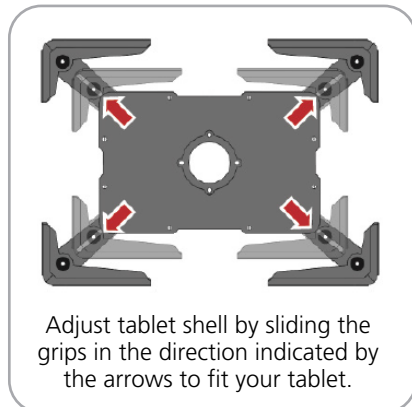

Adjust tablet shell by sliding the grips in the direction indicated by the arrows to fit your tablet.

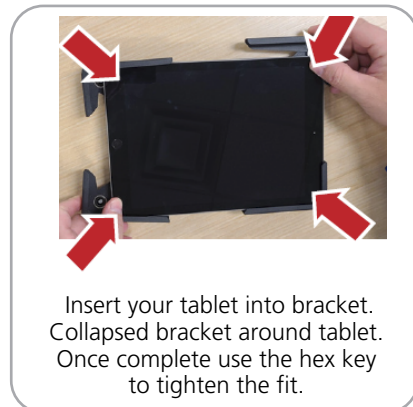

Insert your tablet into bracket. Collapsed bracket around tablet. Once complete use the hex key to tighten the fit.

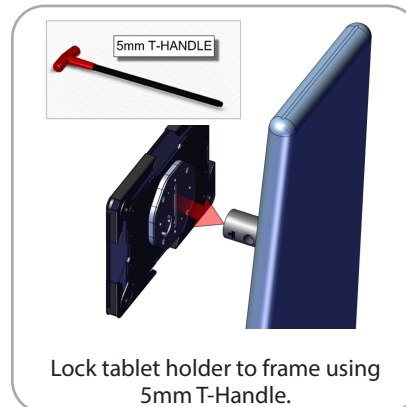

Lock tablet holder to frame using 5mm T-Handle.



Unit is complete.